

**Requirements for Connection of
Facilities to The**



MIDWEST Transmission System

**Version 4
September 2009**

TABLE OF CONTENTS

| | |
|---|-----------|
| 1. INTRODUCTION | 2 |
| 2. TYPES OF CONNECTED CIRCUIT CONFIGURATIONS | 9 |
| 3. DESIGN REQUIREMENTS FOR CONNECTION | 9 |
| 4. REQUIREMENTS FOR OPERATION | 16 |
| 5. PROTECTIVE RELAYING AND COORDINATION | 20 |
| 6. TESTING AND MAINTENANCE COORDINATION | 22 |
| 7. METERING | 22 |
| 8. VOICE COMMUNICATIONS AND PROCEDURES | 25 |
| 9. COSTS INCURRED | 25 |
| 10. DESIGN REVIEW | 26 |
| 11. INSPECTION REQUIREMENTS (EXISTING OR NEW) | 28 |
| 12. FINAL DOCUMENTATION | 29 |
| 13. APPROVALS | 29 |
| 14. SPECIAL PROVISIONS | 29 |
| 15. COORDINATION WITH OTHER CODES, STANDARDS, AND AGENCIES | 29 |
| 16. INDEMNIFICATION | 30 |

APPENDIX A – Connections to Duke Energy Midwest System

APPENDIX B – Generation Dynamic Performance Data

APPENDIX C – Voltage Flicker & Harmonic Distortion Criteria

APPENDIX D – Generation Abnormal Frequency Allowance

APPENDIX E - Revision Record

1. INTRODUCTION

Duke Energy Midwest has prepared this document to outline the minimum requirements for all facilities connecting to the Transmission System.

1.1. Background

Duke Energy Midwest is establishing this document to assist any entity interested in connecting facilities to the Transmission System. In response to changes in state and federal regulations as well as market conditions, there have been an increasing number of requests to connect to and use the Transmission System. The following procedures were established to insure that all requests for transmission interconnection are treated in a consistent and comparable manner. The information contained herein is subject to change and may be revised at any time.

Facility connections to the Transmission System will be provided upon completion of (i) all necessary studies and (ii) construction of the facilities needed to interconnect the new facilities to the Transmission System. Each request for connection to the Transmission System, including requests by Duke Energy Midwest, will be evaluated to make sure system reliability; safety and quality of service are maintained. Studies will be performed to evaluate the facilities needed to connect the new facilities to the Transmission System and any system reinforcements needed to provide the connection. For generation interconnection requests and transmission to transmission interconnection requests, upon completion of all studies the requester, Duke Energy Midwest and the Midwest Independent System Operator (MISO) must also complete an Interconnection Agreement, which will describe the nature of the services provided as a result of the interconnection and the responsibilities of each party.

1.2. Scope

This document informs entities seeking facility connections to the Transmission System of the transmission connection requirements. The requirements are applicable to all facilities connecting to the Transmission System, both those owned by Duke Energy Midwest as well as facilities owned by other parties. Requirements that are specific to generation facilities are noted in the appropriate sections; otherwise this document applies to generation owners, end users or transmission entities requesting to connect to the Transmission System.

For generator interconnection requests, these requirements generally apply to all new generating facilities with a net rating of 10 MW or greater or to modifications of existing generating facilities which increases the net rating by 10 MW or greater. The minimum requirements pertaining to connected facilities are contained herein. Reliability concerns in particular are such that additional requirements may need to

Requirements for Connection of Facilities to the Duke Energy Midwest Transmission System

be imposed on connecting facilities based on their location within the Transmission System, Facility power level and the associated impacts on Transmission System performance. The need for additional requirements can only be evaluated once certain details of a proposed Facility are made known and connection studies have been conducted.

The scope of this document is limited to the technical requirements for connected Facility design and operation. The Midwest ISO's Tariff and Generation Interconnection Business Practices Manual (BPM) includes processes and procedures necessary to establish a generation interconnection and to reserve and secure transmission service and/or generation deliverability. Transmission service and/or generation deliverability is required to move the output of the generator(s) onto or out of the Transmission System. The owner of the Facility securing the generation interconnection need not be the same customer securing Transmission service or deliverability. The Midwest ISO Tariff and BPM can be found at <http://www.midwestiso.org/page/Generator%20Interconnection>.

1.3. Objectives

The procedures included in this document are based on the following objectives:

- 1.3.1. Maintain system reliability, personnel and equipment safety, and quality of service as new facilities are added to the Transmission System and existing facilities are modified.
- 1.3.2. Ensure comparability in the requirements imposed upon the various entities seeking to connect facilities to the Transmission System.
- 1.3.3. Satisfy compliance with NERC and RFC Standards pertaining to documentation of Facility connection requirements by those entities responsible for system reliability.
- 1.3.4. Inform those entities that seek facility connections to the Transmission System of the various requirements for system reliability, safety of personnel and equipment, and quality of service.
- 1.3.5. Facilitate uniform and compatible equipment specification, design, engineering, and installation practices to promote safety and uniformity of service.

1.4. Connection Studies

Since MISO is Duke Energy Midwest's Transmission Provider all requests for generation interconnections to the Duke Energy Midwest transmission system must be filed with MISO. Generation interconnection and transmission service requests over the Duke Energy Midwest transmission system will follow the MISO

Requirements for Connection of Facilities to the Duke Energy Midwest Transmission System

BPM and the scope of the connection studies is determined by MISO and is generally based on the type, location, and power level of the proposed facility. As part of the MISO process Duke Energy Midwest and representatives from other impacted transmission systems will participate in these studies through an ad-hoc study group. A report documenting the assumptions, results, and conclusions of the connection studies will be made available to the requester of the generation interconnection study and will be posted at www.midwestiso.org/page/Generator%20Interconnection. Duke Energy Midwest with coordination with MISO and other impacted transmission systems representatives will generally form an ad-hoc group and perform studies and provide a written summary of the results of the studies involving end user requests to connect to the Duke Energy Midwest transmission system or studies involving requests from other transmission entities to connect to the Duke Energy Midwest transmission system. These studies generally include power flow, short circuit, power quality and stability analysis as required for the particular installation. Duke Energy Midwest will notify adjacent transmission owners and MISO that may be affected by the connection to form an ad-hoc study group. Duke Energy Midwest will share any results of the studies including notification of any new or modified facilities with the ad-hoc study group within required code of conduct rules. These impacted systems may decide to perform their own additional studies. Any disputes between the connecting party and the impacted party must be resolved between the two parties. Duke Energy Midwest will provide any information required to facilitate the dispute resolution.

Requirements for Connection of Facilities to the Duke Energy Midwest Transmission System

1.5. Responsibilities

All Facility Owners will be responsible for the costs associated with connecting to the Transmission System. This will include both the costs of the Facility Owner's facilities and all costs of modifications and/or additions to Duke Energy Midwest transmission facilities required to integrate the facilities. Costs assignments related to generation connections or for customers taking service under the MISO tariff will be handled pursuant to the MISO latest tariff.

1.6. Procedures for Requesting Connection to the Transmission System

1.6.1. Application: A request from a transmission owner or end user to connect to the Duke Energy Midwest transmission system must be submitted by written Application addressed as follows: Attention: Director, Midwest Transmission Planning, Duke Energy, 1000 E. Main Street, Plainfield, IN 46168. All requests for generation interconnection to the Duke Energy Midwest transmission must be submitted to the MISO per MISO procedures (www.midwestios.org).

1.6.2. Completed Application: The following information is required on the request:

- The proposed project name;
- The location (with drawing), type, size (Voltage at point of interconnection, MW and MVAR), and other characteristics of the load such as arc furnace type, power factor of the electric generator(s) or project, proposed interconnection location which indicates specific Duke Energy Midwest transmission line and location of proposed connection point for transmission interconnection requests;
- The expected in-service date;
- Company name and address; and
- Company representative as contact with mailing address, e-mail address and phone number.

Requirements for Connection of Facilities to the Duke Energy Midwest Transmission System

1.7. Definitions

- a) "Change of Ownership" means the point where one owner's rights begin and the other owner's rights cease.
- b) "Duke Energy Midwest" means Duke Energy Business Services, Inc., acting as agent for and on behalf of Duke Energy Ohio (DEO), Duke Energy Kentucky (DEK) and Duke Energy Indiana (DEI), and its permitted successors and assigns.
- c) "Duke Energy Midwest-Owned Interconnection Facilities" means all those facilities or portions of facilities owned by Duke Energy Midwest, from the Interconnection Point up to the Delivery Point, which, in conjunction with the Facility-Owned Interconnection Facilities, are necessary to effect the transfer of power between the Facility and the Transmission System and the provision of ancillary services to the Facility, and shall include any modifications, additions, or upgrades made to those facilities.
- d) "Control Area" means an electric power system or combination of electric power systems to which a common automatic generation control scheme is applied in order to:
 - match, at all times, the power output of the generators within the electric power system(s) and capacity and energy purchased from entities outside the electric power system(s), with the load within the electric power system(s);
 - maintain scheduled interchange with other Control Areas, within the limits of Good Utility Practice;
 - maintain the frequency of the electric power system(s) within reasonable limits in accordance with Good Utility Practice; and
 - provide sufficient generating capacity to maintain operating reserves in accordance with Good Utility Practice.
- e) "Delivery Point" means the point at which the Duke Energy Midwest-Owned Interconnection Facilities are connected to the Transmission System.
- f) "Direct Assignment Facilities" means facilities or portions of facilities that are constructed by the Duke Energy Midwest for the sole use/benefit of a particular Facility Owner requesting a connection to the Transmission System.

Requirements for Connection of Facilities to the Duke Energy Midwest Transmission System

- g) “ECAR” means the East Central Area Reliability Council or any successor organization.
- h) “Emergency” has the meaning customarily attributed to it in the electric utility industry in the United States. It includes, without limitation, any condition on the Facility, the Interconnection Facilities, the Transmission System or the Transmission System of other utilities which is likely to result in imminent significant disruption to service to consumers or is imminently likely to endanger life or property.
- i) “EMS” means Energy Management System, a data acquisition and control computer system maintained and used by Duke Energy Midwest to gather real time information regarding the Transmission System and to provide remote control of individual Duke Energy Midwest switching devices and generating units. The EMS also acts as an accounting and detailed calculation platform to refine and store data.
- j) “Facilities Construction Agreement” means the agreement that details the costs, construction schedule and responsibilities of each party during the construction of the Interconnection Facilities.
- k) “Facility” means the substation, generation (if applicable) and other facilities to be constructed, owned, and operated by the Facility Owner.
- l) “Facility-Owned Interconnection Facilities” means all those facilities or portions of facilities owned by Facility Owner, from the Facility up to the Interconnection Point, which, in conjunction with the Duke Energy Midwest-Owned Interconnection Facilities, are necessary to effect the transfer of power between the Facility and the Transmission System.
- m) “Facility Owner” means the organization that is the actual owner of the facilities being connected into the Transmission System.
- n) “Flicker” means low frequency voltage fluctuations that can be observed through changes in intensity or color of illumination. Flicker is measured using an IEC flicker meter.
- o) “Generation” means the electrical capacity and energy produced at the Facility, if applicable.
- p) “Generator Capability Curve” means the production of megawatts and megavars throughout its output range, which is typically provided by the manufacturer of the generating unit.
- q) “Good Utility Practice” means any of the practices, methods and acts engaged in or approved by a significant portion of the electric utility industry in the United States. These practices may occur during the relevant time period, or any of the practices, methods and acts, which, in the exercise of reasonable judgment in light of the facts known at the time the decision was made. They could have been expected to accomplish the desired result at a reasonable cost consistent with good business practices, reliability, safety and expedition. Good Utility

Requirements for Connection of Facilities to the Duke Energy Midwest Transmission System

Practice is not intended to be limited to the optimum practice, method, or act to the exclusion of all others, but rather includes all acceptable practices, method, or acts generally accepted in the region. Good Utility Practice shall include, but not be limited to, NERC, RFC, ISO, and National Electrical Safety Code criteria, rules and standards, as they may be amended from time to time, including the rules and guidelines and criteria of any successor organizations.

- r) “Harmonics” means the content of a signal whose frequency is an integer multiple of the actual system frequency, i.e. the main frequency produced by the generators or for the United States, 60 cycles per second.
- s) “Interconnection Agreement” means the agreement that documents the physical interconnection between the Facility Owner (if a generator owner or transmission entity) and Duke Energy Midwest, and defines the continuing responsibilities and obligations of the Facility Owner and Duke Energy Midwest during the term of the agreement.
- t) “Interconnection Facilities” means the Duke Energy Midwest-Owned Interconnection Facilities and the Facility-Owned Interconnection Facilities collectively.
- u) “Interconnection Point” means the Change of Ownership point at which point the Facility-Owned Interconnection Facilities are connected to the Duke Energy Midwest-Owned Interconnection Facilities.
- v) “ISO” means the Midwest Independent Transmission System Operator, Inc. or any other independent system operator or regional transmission organization or group to which the Transmission System becomes subject to or parts of, or any successor organization(s).
- w) “Metering Point” means the point at which the amount of Generation delivered to the Transmission System is measured, or the amount of load delivered to the customer or the amount of power exchanged between Duke Energy Midwest and another transmission entity.
- x) “NERC” means the North American Electric Reliability Corporation or any successor organization.
- y) “OATT” means the Duke Energy Midwest or the MISO Open Access Transmission Tariff as filed with the Federal Energy Regulatory Commission, and which maybe modified from time to time.
- z) “Party” means Facility Owner or Duke Energy Midwest, and their permitted successors and assigns.
- aa) “RFC” means Reliability *First* Corporation or any successor organization.
- bb)
- cc) “SCADA” means Supervisory Control and Data Acquisition system.

Requirements for Connection of Facilities to the Duke Energy Midwest Transmission System

- dd) "Transmission System" means the transmission facilities owned, operated or controlled by Duke Energy Midwest, including conductors, circuit breakers, switches, transformers and other associated equipment used to control the transfer of energy from one place to another, and shall include any modifications, additions, or upgrades made to those facilities.
- ee) Any term used in the plural has the same meaning as the singular definition.
- ff)

2. TYPES OF CONNECTED CIRCUIT CONFIGURATIONS

The typical connection between the Facility-Owned Interconnection Facilities and the Transmission System will be designed in a way to minimize the adverse reliability impacts to the Transmission System. It will also allow Duke Energy Midwest to operate the Transmission System without degradation in the event of failure of the Facility. Typical arrangements for facilities connected to existing Duke Energy Midwest substations include breakered straight bus, a breaker and a half bus, and a breakered ring bus as shown in of Appendix A, Figure 1. Likewise, connections of facilities to an existing transmission line are shown in Appendix A, Figure 2. These figures illustrate some of the acceptable configurations for connection to the Transmission System. Actual configurations may vary depending on the location of the Interconnection Point and the Transmission System schemes already in place.

3. DESIGN REQUIREMENTS FOR CONNECTION

The Facility Owner is responsible for installing appropriate equipment and facilities so that the Facility does not degrade Duke Energy Midwest's safety and operating standards. The Facility Owner is also responsible for meeting any applicable federal, state, and local codes along with any applicable NERC, RFC or ISO requirements. The minimum Transmission System connection requirements are as follows.

3.1. Frequency

Generators shall provide balanced, symmetrical, three-phase power at a nominal frequency of 60 Hz.

3.2. System Protection

Requirements for Connection of Facilities to the Duke Energy Midwest Transmission System

Protective relaying is required to protect personnel and equipment from the effects of hazards introduced to the Transmission System through natural and man made events. The protective relaying should be set such as to isolate the piece of faulty equipment as quickly as possible by operating the minimum number of devices and minimizing the effect to the rest of the interconnected power system. The Facility Owner is responsible for providing adequate protection to its facilities and to Duke Energy Midwest-Owned Interconnection Facilities under any transmission operating condition, whether or not their facilities are in operation. Configurations which result in a "three terminal" protective relaying scheme are generally not permitted because of degraded fault clearing performance on the Duke Energy Midwest transmission system and the added complexity of the schemes. See Section 5 for more protective relaying requirements.

3.3. Interrupting Device/Breaker Duty

The Facility Owner shall provide three-phase circuit interrupting device(s) with appropriate protective relaying systems (as stated in Section 5). The device(s) shall isolate the Facility from the Duke Energy Midwest electrical system for all faults, loss of Duke Energy Midwest supply, or abnormal operating conditions (listed in Section 3.2) regardless of whether or not the Facility is operating.

This device shall be capable of interrupting the greater of the maximum available fault current at that location available from the Transmission System or from the Facility. Duke Energy Midwest will provide the following short circuit data for the Delivery Point: 3 phase fault MVA and single line to ground fault amps. The three-phase device shall interrupt all three phases simultaneously and shall have maximum operation time of 2 cycles or less from time of energization of the trip coils(s). The tripping control of the circuit-interrupting device shall be powered independently of the Transmission System or Facility AC sources in order to permit operation upon loss of the Transmission System connection or the Facility AC supply. The protective trips to the interrupting device should be arranged into two independent trip circuits including separate relay trips, separate DC control busses and two trip coils. (see Section 3.6).

Generally, automatic reclosing of the Facility's interrupting device is not desired. If the Facility's configuration requires automatic reclosing, Duke Energy Midwest will provide the specific reclosing times for the Facility's interrupting devices. It is the Facility Owner's responsibility to design and maintain there interrupting device(s), contingent on Duke Energy Midwest approval, to properly isolate the Facility upon loss of the Duke Energy Midwest connection until the appropriate Duke Energy Midwest facilities are returned to service.

3.4. Surge Protection/Insulation Coordination

Requirements for Connection of Facilities to the Duke Energy Midwest Transmission System

The minimum substation/line Basic Insulation Levels (BIL) and arrester ratings are shown below to be used for insulation coordination.

Substation/Line BIL Ratings For Equipment

| Nominal System Voltage | Substation Bus B.I.L. KV | Bank Arrester KV | Line Arrester KV | Line KV | Switch Rating | Transformer B.I.L (kV) Internal |
|------------------------|--------------------------|------------------|------------------|---------|---------------|---------------------------------|
| 138 | 550 | 108 | 108 | 700 | 115 | 550/550 |
| 230 | 900 | 180 | 180 | 1250 | 230 | 825/900 |
| 345 | 1300 | 276 | 276 | 1550 | 345 | 1050/1300 |
| 765 | 2050 | 588 | 588 | N/A | 765 | 1800/2050 |

3.5. System Grounding

The Facility must be electrically grounded in such a way that coordination is maintained with the Duke Energy Midwest protective relay system, and that Duke Energy Midwest facilities will be protected from deleterious voltages during fault conditions. Specific grounding requirements will be established on a case-by-case basis.

3.6. Voice Communication Circuit

The Facility Owner may be required to establish a dedicated voice communication circuit from the Facility to the Duke Energy Midwest System Control Center ("SOC") to permit coordination of the synchronization and operation of the Facility.

Requirements for Connection of Facilities to the Duke Energy Midwest Transmission System

3.7. Disconnecting Devices

All generator connections to the Duke Energy Midwest system require a three-phase motor operated air break switch. The disconnecting device is to be supervisory controllable from the Duke Energy Midwest SOC. The disconnecting device shall be mechanically lockable in the open position with a Duke Energy Midwest padlock in order to provide a visible, physical electric isolation of the Facility. When the disconnecting device is operated to the open position, Duke Energy Midwest must be able to remotely disable all tripping signals and return Duke Energy Midwest's system to a normal operating state. The disconnecting device shall be identified with a designated equipment number acceptable to Duke Energy Midwest naming convention and must be accessible to Duke Energy Midwest at all times. For non-generator connections to the Duke Energy Midwest system, Duke Energy Midwest may require that the disconnecting device be equipped with motor operators and with capability to be supervisory controlled from the Duke Energy Midwest SOC.

3.8. Disturbance Monitoring

In order to determine the performance of the overall Transmission System and to determine causes of system disturbances, RFC may require the installation of disturbance monitors at specific locations and specific types (e.g. fault recording or dynamic recording). The Facility must install disturbance-monitoring equipment with sufficient capability to permit adequate analysis of electrical disturbances on the Transmission System as required by RFC. The Facility Owner is responsible for meeting other RFC requirements related to disturbance monitoring equipment per ECAR Document 14 and NERC Standard VAR-002(available at www.rfirst.org).

3.9. Transient Stability Performance

Transient stability performance of generators is the responsibility of the generator owner. Transient stability performance should be in accordance with Duke Energy Midwest's transient stability criteria, which is provided in Duke Energy Midwest's FERC Form 715.

3.10. Excitation Control

For generators, each unit in the Facility must be equipped with an Automatic Voltage Regulator (AVR). The excitation system must always be operated in the automatic voltage control mode unless approved otherwise by Duke Energy Midwest or the ISO. Generating plants with a total net summer demonstrated capacity of less than 100 MW will be exempt from this requirement. In addition to the normal excitation system and automatic voltage regulation equipment, the following controls are also required for each synchronous generator:

Requirements for Connection of Facilities to the Duke Energy Midwest Transmission System

3.10.1. Overcurrent Limiter

The excitation system is to be provided with a current limiting device which will supercede or act in conjunction with the AVR to automatically reduce excitation so that generator field current is maintained at the allowable limit in the event of sustained under-voltages on the Transmission System. This device must not prevent the exciter from going to and remaining at the positive ceiling following the inception of a fault on the power system. The amount of time that the exciter is allowed to remain at the positive ceiling shall be provided to Duke Energy Midwest upon request.

3.10.2. Underexcitation Limiter

A limiter to prevent instability resulting from generator underexcitation is required.

3.10.3. Power System Stabilizer

MISO and/or Duke Energy Midwest studies may identify the need for the use of power system stabilizers, depending on the plant size, excitation system type and settings, Facility location, area transmission system configuration and other factors. This will be determined on a case-by-case basis.

3.11. Speed Governing

All synchronous generators connected to the Duke Energy Midwest transmission system shall be equipped with speed governing capability. This governing capability shall be unhindered in its operation consistent with overall economic operation of the Generation. See also NERC Standard VAR-002 Overspeed protection in the event of load rejection is the responsibility of the Facility Owner.

3.12. Dynamic Performance Data

For generators, dynamic performance data shall be made available to MISO and Duke Energy Midwest. This data is required to evaluate the system dynamic performance of the Facility, which includes but is not limited to transient stability. See Appendix B for data required. The Facility Owner shall submit dynamic performance data per MISO Tariff Attachment X.

Requirements for Connection of Facilities to the Duke Energy Midwest Transmission System

3.13. Generator Step-Up and Auxiliary Transformers

For generators requesting connection to the Duke Energy Midwest transmission system, the owner must supply tap settings, available tap ranges and impedance data for generator step-up and upon request for auxiliary transformers. Duke Energy Midwest may require changes to the tap settings and will notify the generator owner of the change along with a technical justification for the change. Generating plants with a total net summer demonstrated capacity less than 100 MW will generally be excluded from these reporting requirements.

3.14. Automatic Generation Control (AGC)

For generators, depending upon various Control Area factors applicable to tie line and frequency regulation, provisions for dispatch control of Generation by Duke Energy Midwest, AGC system may be required. This will be considered on a case-by-case basis and any provision for control by AGC shall be included in an Interconnection Agreement between the Facility Owner, MISO and Duke Energy Midwest.

3.15. Black Start Capability

For generators requesting connection to the Duke Energy Midwest transmission system, depending upon the Facility connection, location and other factors applicable to system restoration in the event of a blackout, the provision of black start capability may be desirable. A black start capable generation facility is one that can be started without the aid of off-site power supplied by the Transmission System. However, with or without black start capability, the generator is expected to participate in system restoration efforts in the event of a system wide blackout. As a minimum, the generator will be expected to have the ability to synchronize units to the Transmission System in the frequency range identified in section 4.1. The generator must also be capable of operating at low output levels, and participate in frequency control of the system instead of base loading the unit. Responsibilities of the generator for black start capability will be addressed in the Interconnection Agreement.

3.16. Sub-Synchronous Torsional Interactions or Resonances

For generators, depending upon the specific location of the Facility in the Transmission System, close electrical proximity to series compensated transmission lines or FACTS devices may result in undesirable or damaging sub-synchronous currents. Also, the provision of high speed reclosing following transmission line faults may result in excessive torsional duties. The generator

Requirements for Connection of Facilities to the Duke Energy Midwest Transmission System

must provide Duke Energy Midwest with immunity from damaging torsional oscillations resulting from all Transmission System operations, and insure that the turbine-generator is not excited into resonance by normal system operations. The Interconnection Agreement shall address these matters.

3.17. Unbalanced Electric Conditions

3.17.1. Voltage Balance

For generators, all three-phase generation shall produce balanced 60 Hz voltages. Voltage unbalance attributable to the Facility's combined generation and load shall not exceed 1.0% measured at the Interconnection Point. Voltage unbalance is defined as the maximum phase deviation from average as specified in ANSI C84.1, "American National Standard for Electric Power Systems and Equipment – Voltage Ratings, 60 Hertz."

3.17.2. Current Balance

Phase current unbalance attributable to the Facility's combined generation and load shall not exceed that which would exist with balanced equipment in service, measured at the Interconnection Point.

3.18. Harmonics and Flicker (Power Quality)

3.18.1. The Facility Owner shall take responsibility for limiting Harmonic voltage and current distortion and/or voltage Flicker¹ caused by their equipment. Specific Duke Energy Midwest Harmonics and Flicker criteria are given in Appendix C.

¹ Flicker is low frequency voltage fluctuations that can be observed through changes in intensity or color of illumination. Flicker is measured using an IEC flickermeter.

Requirements for Connection of Facilities to the Duke Energy Midwest Transmission System

- 3.18.2. Limits for Harmonic distortion (including inductive telephone influence factors) are consistent with those published in the latest issues of ANSI/IEEE 519, "Recommended Practices and Requirements for Harmonic Control in Electrical Power Systems."
- 3.18.3. Acceptance of Flicker emissions by the Facility Owner shall follow IEC 61000-3-7, "Assessment of emission limits for fluctuating loads in MV and HV power systems." Compatibility levels for LV (≤ 1 kV) Flicker are Pst = 1.0 and Plt = 0.8. Planning levels for MV ($1\text{kV} < V \leq 35\text{kV}$) Flicker are Pst = 0.9 and Plt 0.7. Planning levels for HV and EHV ($> 35\text{kV}$) are Pst = 0.8 and Plt = 0.6.
- 3.18.4. Depending upon the nature of the Facility and its location, Duke Energy Midwest may require the installation of a monitoring system to permit ongoing assessment of compliance with these criteria. The monitoring system, if required, will be installed at the Facility Owner's expense.
- 3.18.5. Situations where high voltage Flicker, high harmonic voltages and/or high harmonic currents originate from the Transmission System are to be addressed in the Interconnection Agreement.

4. REQUIREMENTS FOR OPERATION

The Facility Owner will be responsible for operating their Facility in a safe manner, and with full cooperation under the supervision of the Duke Energy Midwest operation centers, security coordinators or independent regional system operation center. The Facility will notify the Duke Energy Midwest SOC and Duke Energy Midwest's Control Area Operations before any planned startup or shutdown of generation at the Facility and as soon as practical after the onset of an unplanned shutdown or trip of the facilities. For generators, the Facility Owner will also notify Duke Energy Midwest as soon as practical regarding the removal of any faulted equipment from the Facility associated with the high voltage side of the step-up transformer. A Facility generator shall not synchronize to, nor supply power into, the Transmission System unless a specific agreement has been made to supply power to the Transmission System in accordance with appropriate open access transmission tariffs.

Only under the direct supervision of the SOC will the Facility at any time energize any part of the Transmission System facilities that have been de-energized. Failure to comply has the potential to cause hazard or injury to personnel or to the public as well as damage to equipment and thus make the Facility Owner liable for such damages.

The minimum requirements for operation of facilities on the Transmission System are contained herein.

Requirements for Connection of Facilities to the Duke Energy Midwest Transmission System

4.1. Synchronization

The Facility Owner will own, test, and maintain equipment that will synchronize the facilities to the Transmission System. The Facility Owner assumes all responsibility for properly synchronizing their facilities with the Transmission System. Upon loss of the Duke Energy Midwest supply, the Facility shall immediately be separated from the Transmission System. Synchronizing of facilities to the Transmission System may be, at Duke Energy Midwest's discretion, performed under the direction of the Duke Energy Midwest SOC.

4.2. Net Demonstrated MW Capability - Generators

The Facility Owner shall provide the net demonstrated real power capability annually to Duke Energy Midwest in accordance to testing procedures outlined in the ECAR Document #4 and NERC/RFC Standard MOD-0024-RFC-01. Other generator parameters must also be provided as required.

4.3. Voltage Schedule or Reactive Control Requirements

For generators, Duke Energy Midwest will provide a voltage range schedule to the Facility that will be set on a time of day and day of week basis, and may be revised from time to time by Duke Energy Midwest. Any necessary deviation from the schedule for the safe and reliable operation of the Transmission System will be communicated to the Facility by the Duke Energy Midwest SOC. In general this voltage schedule will not request operation outside plus or minus 5% of the nominal Transmission System voltages of 345, 230, 138 (132 for DEO), and 69 (66 for DEO & DEK) kV.

Under certain conditions where a voltage schedule is inappropriate, Duke Energy Midwest may substitute adherence to a specified voltage schedule with a specified power factor.

4.3.1. Automatic Voltage Regulation - Generators

Unless otherwise agreed to, the Facility Owner will operate the generators with automatic voltage regulators consistent with Good Utility Practice. The voltage regulators will control voltage at the Interconnection Point consistent with the voltage schedule provided. Status of automatic voltage regulator (auto/manual or normal/abnormal condition) shall be provided to the Transmission Provider via EMS. Generating plants with a total net summer demonstrated capability less than 100 MW will generally not be provided with a voltage schedule.

Requirements for Connection of Facilities to the Duke Energy Midwest Transmission System

4.3.2. Voltage Range

Generators must be capable of continuous non-interrupted operation within a steady-state voltage range at the high side of the generator step-up transformer during system normal and single facility outage conditions. This range is from 90% to 105% of the nominal transmission voltage. Duke Energy Midwest's nominal system voltages are as indicated in Section 4.3 above. During Emergency and/or transient system conditions, when voltage may temporarily be outside of the 90% to 105% range, all reasonable measures should be taken to avoid tripping the Facility due to high or low voltage.

Duke Energy Midwest's transmission system is designed to operate between 90% and 105% of nominal voltage during normal and single contingency conditions. If the requirements of the Facility Owner's equipment are more restrictive than these limits, then Duke Energy Midwest recommends the Facility Owner consider the installation of voltage regulation devices.

4.3.3. Reactive Power Factor and Power Factor Control

Unless otherwise agreed to, generators are to have the capability to sustain operation with an under-excited power factor of -0.90 or less and over-excited power factor of 0.95 or less, as measured at the high side of the generator step-up transformer. The generator must be able to achieve these rated power factors throughout its output range in accordance with testing outlined in ECAR Document #4 and NERC/RFC Standard MOD-025-RFC-01. For end users, the expected power factor of their load must be provided to Duke Energy Midwest. Depending on the location on the transmission system, Duke Energy Midwest may require the end user to improve its power factor and power factor control. For connections with transmission systems, reactive flow between the two systems will be addressed in the interconnection agreement. In general the connecting transmission system shall acquire sufficient reactive resources within its system to protect the voltage levels under normal and contingency conditions. This includes the transmission system share of the reactive requirements of interconnecting transmission circuits.

4.4. Frequency Range

Unless otherwise agreed to, the generators must provide support to maintain system frequency at or near 60 hertz. The Facility must be capable of continuous operation in the frequency range of 59.5 to 60.5 hertz. For generators, limited time operation outside this range must be maintained in accordance with the generator manufacturer's recommendation or the figure contained in Appendix D.

Requirements for Connection of Facilities to the Duke Energy Midwest Transmission System

4.5. Scheduled Outages and Maintenance Coordination

The Facility Owner is to consult with the Duke Energy Midwest System Operations Center (“SOC”) for any scheduled Facility outages that affect the Transmission System and provide the annual outage/maintenance schedule for generators. The SOC will consult with the Facility Owner regarding the timing of scheduled maintenance of the Transmission System facilities that might reasonably be expected to affect the Facility-Owned Interconnection Facilities.

4.6. Switching, Tagging, Grounding, and Isolation Rules

The Facility will comply with Duke Energy Midwest’s Switching, Tagging, and Isolation Procedures as Duke Energy Midwest may modify them from time to time. Duke Energy Midwest will provide the Facility Owner an initial one-time training of these procedures. Details of requirement and additional training requests will be covered under the Interconnection Agreement.

4.7. Other Applicable Operating Requirements

In order to assure the continued reliability of the Transmission System, the Facility may be requested to adhere to other operating requirements and/or common operating practices. These may include the performance not to exceed a specified forced outage rate, operations procedures during system emergencies, participation in Control Area operating reserves, provisions for backup fuel supply or storage, and provisions for Emergency availability identified by the North American Electric Reliability Council. (NERC)². Duke Energy Midwest may require the Facility to provide Interconnected Operation Services defined by NERC under Policy 10. Such requirements shall be addressed in the Interconnection Agreement with the Facility.

Conformance with applicable requirements in NERC and RFC Standards and Documents, particularly NERC Standards MOD-024(&025)-RFC-01, VAR-002, PRC-002-RFC-01, ECAR Document 4, “Criteria and Methods for the Uniform Rating of Generation Equipment,” and, ECAR Document 14, “Disturbance Monitoring Equipment,” is required. All data reportable to RFC and/or NERC shall also be made available to Duke Energy Midwest.

4.8. Break-Before-Make Transfer

In the cases where the Facilities have connections with another transmission system, the Transmission System will not be operated in parallel with this other transmission system by any action of the Facility unless such an agreement is in

² North American Electric Reliability Council, “Reliability Considerations for Integrating Non-Utility Generating Facilities with the Bulk Electric Systems,” January 1992.

Requirements for Connection of Facilities to the Duke Energy Midwest Transmission System

place between the Facility, the other transmission system, and Duke Energy Midwest. All Facility connection transfers between Duke Energy Midwest and the other transmission system must be a de-energized transfer (break-before-make type of transfer). Requests for any hot transfer (make-before-break transfer) or interconnected operation with another transmission system will be addressed in the Interconnected Agreement.

4.9. Transmission Tariffs

Duke Energy Midwest has in place an OATT that was approved by FERC on September 16, 1998 to provide transmission service. The MISO also has a tariff filed with FERC. These tariffs contain the rates for transmission services, including rates for ancillary services offered by Duke Energy Midwest and the ISO.

4.10. Operating Restrictions

Duke Energy Midwest reserves the right to request that the Facility reduce its output of Generation or to disconnect service to any Facility when consistent with Good Utility Practice and when necessary to alleviate any transmission constraint or Emergency. This will also be addressed in the Interconnection Agreement.

5. PROTECTIVE RELAYING AND COORDINATION

The protective relaying scheme for interfacing with Duke Energy Midwest facilities will be determined on a case-by-case basis, based on the location, size of the facility, interconnection voltage, and configuration. Duke Energy Midwest will provide functional and performance requirements and in some cases relay settings for protective relays at the Facility Owner facilities that can have an impact on the reliability of the Transmission System. The functional requirements and relay settings will be based upon those outlined in NERC Standards PRC-001,-004,-005 and Duke Energy Midwest's protection philosophy. Duke Energy Midwest reserves the right to specify the protective relay type and manufacturer.

5.1. Owner Facilities

The Facility Owner is solely responsible for protecting its own equipment in such a manner that electrical faults, disturbances, inadvertent phase unbalance, single phasing, or operations on the Transmission System do not cause damage to the Facility Owner's equipment.

The Facility Owner's protection scheme shall be designed to separate their system from the Transmission System under the following conditions:

- For faults within the Facility Owner's equipment in the protection zone which overlaps the interconnection.

Requirements for Connection of Facilities to the Duke Energy Midwest Transmission System

- For faults in the adjacent Duke Energy Midwest owned or operated system which overlaps the interconnection.
- Whenever the Duke Energy Midwest supplied electrical source is unavailable.

The interconnect relays must be dedicated to protection of the interconnection and separate from any relays applied to the facility, even if this results in redundant relay functions.

The protective relays required by Duke Energy Midwest and any auxiliary-tripping relay associated with those relays shall be utility-grade devices. Utility grade relays are defined as follows:

1. Meet ANSI/IEEE Standard C37.90, "Relays and Relay Systems Associated with Electric Power Apparatus."
2. Have relay test facilities to allow testing without unwiring or disassembling the relay.
3. Have appropriate test plugs/switches for testing the operation of the relay.
4. Have targets to indicate relay operation.

Duke Energy Midwest may elect to specify settings, or alternatively may elect to review and approve Facility Owner specified relay settings for the Duke Energy Midwest-required relays to assure coordination between the Facility protective equipment and the Transmission System relays. It is the Facility Owner's responsibility to determine that their internal protective equipment coordinates with the required Duke Energy Midwest protective equipment and is adequate to meet all applicable standards to which the Facility is subject. Duke Energy Midwest further reserves the right to modify relay settings when deemed necessary to avoid safety hazards to utility personnel or the public and to prevent any disturbance, impairment, or interference with Duke Energy Midwest's ability to serve other customers.

5.2. Duke Energy Midwest Facilities

If at any time it is determined that the use of the above relay systems cannot provide adequate protection to the Duke Energy Midwest system, the Facility Owner shall, at their expense, furnish and install additional relaying as requested by Duke Energy Midwest. This may include a transfer trip receiver(s) at the Facility-Owned Interconnection Facilities to receive tripping signals originating from a Duke Energy Midwest location(s). This additional protection would also necessitate, at the Facility Owner's expense, the purchase and installation of transfer trip equipment at the Duke Energy Midwest location(s) and a

Requirements for Connection of Facilities to the Duke Energy Midwest Transmission System

communication channel between the Duke Energy Midwest location(s) and the Facility.

5.3. Other Protection Requirements

See NERC Standards PRC-001, -004, 005 and VAR-002 (Available at www.rfirst.org)

6. TESTING AND MAINTENANCE COORDINATION

A Duke Energy Midwest approved organization shall test and maintain the relays, devices and control schemes, provided by the Facility Owner, for the protection of the Transmission System. The equipment to be tested and maintained may include circuit breakers, circuit switches, power fuses, instrument transformers, switches, surge arresters, bushings, relays, and associated equipment (including battery and battery charger). The testing and maintenance may include any initial set up, calibration, and check out of the required protective devices, periodic routine testing and maintenance, and any testing and maintenance required as the result of changes to protective devices by the Facility Owner or Duke Energy Midwest.

Duke Energy Midwest reserves the right to be present for all testing and maintenance performed by the Duke Energy Midwest approved organization. A copy of all test and maintenance reports shall be forwarded to Duke Energy Midwest.

If the Facility Owner's testing and maintenance program is not performed to the satisfaction of Duke Energy Midwest or at the required maintenance interval, Duke Energy Midwest reserves the rights to inspect, test, or maintain the protective devices required for the protection of the Transmission System. If the Facility Owner's protective relaying is determined to be unsatisfactory, Duke Energy Midwest reserves the authority to disconnect the Generation from the Duke Energy Midwest system.

All costs associated with the testing and maintenance of devices provided by the Facility Owner for the protection of the Transmission System, including costs incurred by Duke Energy Midwest in performing any necessary tests or inspections, shall be the responsibility of the Facility Owner.

See NERC Standards PRC-001, -004, 005, for information on maintenance and testing of protection schemes.

7. METERING

Metering

7.1. Responsibilities.

Requirements for Connection of Facilities to the Duke Energy Midwest Transmission System

At Facility Owner's expense, Duke Energy Midwest will install, own, operate, and maintain all metering and telemetering equipment. Facility Owner shall also provide space for required equipment. Additional metering and RTU and communication requirements for transmission interconnections are provided in the [Duke Energy Midwest Engineering Guide – Interconnection Metering](#). A copy of this document will be provided to the requesting transmission entity.

7.2. Equipment Requirements.

Such metering equipment shall include standard types of meters, potential and current transformers, test switches, and such other appurtenances as necessary to provide instantaneous values of megawatts and megavars and an automatic record of megawatt-hours for each clock hour. To the extent there is a possibility of flows of electricity in either direction, such metering equipment shall provide metering data for each direction of flow. The timing devices of all meters shall be maintained in Eastern Standard Time (EST) and shall be synchronized as closely as practicable.

7.3. Accuracy.

The accuracy of the instrument transformers will be 0.3 percent or better, and the accuracy of the meters and transducers will be 0.2 percent or better. The secondary wiring and burdens of the metering equipment will be configured so that they do not degrade the accuracy of the metering equipment. Revenue meters will be equipped with mass memory storage for backup data in the event of communications problems. If any metering equipment is found to be inaccurate by a margin of greater than that allowed under any applicable ISO, RFC, or Duke Energy Midwest criteria, rules and standards, Duke Energy Midwest shall cause such metering equipment to be made accurate or replaced. In the event of a conflict between ISO, RFC, or Duke Energy Midwest criteria, ISO criteria shall govern.

7.4. Testing and Sealing of Meters.

All revenue metering equipment installed shall be routinely tested and calibrated, and its accuracy of registration maintained, by Duke Energy Midwest in accordance with Good Utility Practice and applicable ISO and Duke Energy Midwest criteria, rules and standards. All meters shall be sealed and may be broken only by Duke Energy Midwest on such occasions when the meters are to be inspected, tested, calibrated, or adjusted. Each Party shall comply with any reasonable request of the other concerning the testing, calibration and sealing of meters, the presence of a representative of the other Party when the seals are broken and tests are made, and other matters affecting the meters. If either Party believes that there has been a meter inaccuracy, failure, or stoppage, that Party shall immediately notify the other.

Requirements for Connection of Facilities to the Duke Energy Midwest Transmission System

7.5. Location of Equipment.

Unless otherwise agreed upon, the location of the metering equipment will be at the Interconnection Point. If the Metering Point and the Interconnection Point are not at the same location, the metering equipment shall record measurements in a manner that accounts for losses occurring between the Metering Point and the Interconnection Point. Losses occurring between the Metering Point and the Interconnection Point shall be allocated pursuant to the applicable tariff.

7.6. Cost For Additional Equipment.

Any additional required facilities, including required communication channels and equipment, shall be furnished and installed at the Facility Owner's expense.

Data Acquisition and Control Information

7.7. Responsibilities.

At Facility Owner's expense, Duke Energy Midwest approved telemetering and backup telemetering equipment will be installed at the Metering Point to provide real-time data to Duke Energy Midwest's EMS and to all other participating parties. Facility Owner is also responsible for providing data to Duke Energy Midwest's EMS, by means of a remote terminal units ("RTU") or other approved method.

7.8. Required Equipment.

Telemetering equipment could include transducers, RTUs, modems, telecommunication lines, and any other equipment providing equal or better functionality. The RTU, or equivalent device, must have multiple communication ports to allow simultaneous communications with all participating parties. That device will accommodate Duke Energy Midwest's data communication requirements, including communication protocol, rate and mode. Backup metering, backup RTUs and communication links compatible with Duke Energy Midwest's communication system, will be provided in case of problems with the primary equipment. Backup metering will utilize separate instrument transformers and transducers from primary metering, for MW and MVAR values.

7.9. Required Data.

Data acquisition and control information will typically include, but not limited to:

1. Desired Generation MW set point for generators.
2. Automatic Generation control (AGC) status for generators.
3. Generator availability for generators.
4. Generation gross MW, MVAR output for generators.
5. Auxiliary MW, MVAR data for generators.
6. Generator minimum and base MW capability for generators.

Requirements for Connection of Facilities to the Duke Energy Midwest Transmission System

7. Generator MW AGC high/low limit for generators.
8. Interconnection Point breaker and disconnect switch status/control/alarms.
9. Interconnection Point MW, MVA_r, voltage, and amperes.
10. Generator (if applicable) and substation metering (MWhr and MVA_rhr) data.

8. VOICE COMMUNICATIONS AND PROCEDURES

8.1. Normal Operating Conditions.

At Duke Energy Midwest's request, Facility Owner of generating facility shall be responsible for providing, at its expense, a dedicated voice communication circuit to the Duke Energy Midwest SOC located in either Cincinnati, Ohio or Plainfield, Indiana. Such a dedicated voice communication circuit would originate from the Facility Owner's 24 hour manned operations office, and would be typically required for Facility synchronization and operation within Duke Energy Midwest's Control Area. All other normal voice communication concerning Facility operations shall be conducted through the public telephone network to the Duke Energy Midwest SOC.

8.2. Emergency Operating Conditions.

Voice communications in the event of a transmission facility Emergency shall use the dedicated voice circuits, if available or public telephone network and phone number(s) designated for Emergency use.

- 8.2.1. In the event of a Transmission System or capacity Emergency, the Facility Owner may be notified by Duke Energy Midwest's SOC. Specific instructions may also be given regarding the operation of the Facility Owner's equipment. It is the Facility Owner's responsibility to ensure that the unit operators follow all instructions given by Duke Energy Midwest's SOC during these emergencies.

9. COSTS INCURRED

The Facility Owner shall reimburse, pursuant to the OATT where applicable, all costs incurred by Duke Energy Midwest to provide an interconnection of their Facility to the Transmission System. The costs include but are not limited to:

1. Each review of the engineering and engineering drawings associated with the Facility.
2. All metering not covered under the OATT of general applicability.

Requirements for Connection of Facilities to the Duke Energy Midwest Transmission System

3. All necessary facility modifications on the Transmission System to adequately accommodate the interconnection of the Facility Owner's facilities.
4. All communications circuits required for telemetering, protective relaying, and/or voice communications with the Facility.
5. All protective relaying and devices required for the protection of the Transmission System due to the addition of the Facility.
6. All protective relaying required for protecting the Facility from faults and abnormal system operating conditions.
7. Duke Energy Midwest equipment replacements or modifications due to an increase in available short circuit fault current directly caused by the addition of the Facility Owner's equipment.
8. Calibration, testing, and maintenance of relays and protective devices provided by the Facility Owner for the protection of the Transmission System.
9. All telemetering equipment to provide necessary telemetry to the Duke Energy Midwest SOC.
10. All studies performed by Duke Energy Midwest pertaining to the Facility.

10. DESIGN REVIEW

The Facility Owner is responsible for submitting all specifications and detailed plans to Duke Energy Midwest for review and approval prior to receiving permission to connect to the Transmission System.

Duke Energy Midwest requires notification in letter form for the proposed installation of any Generation, including an Emergency generator utilizing a make-before-break transfer switch. In order to allow for timely exchange of information, this notification should be provided during the preliminary planning stages of the proposed Facility.

10.1. Notification of Intent

Within at least six (6) months prior to the proposed in-service date of the facility, the Facility Owner is required to complete and forward a Notification of Intent to Install and Operate Facilities (NIOF) to the Director, Bulk Transmission Planning with all necessary attachments, which shall include:

Requirements for Connection of Facilities to the Duke Energy Midwest Transmission System

1. A summary signed by the Facility Owner management that provides a general description of the intended manner of operation for the Facility.
2. Three copies of drawings and specifications prepared and approved by a registered professional engineer adequately detailing the Facility location and proposed location of the facilities with respect to the Facility Owner's desired Interconnection Point and the appropriate disconnecting devices identified in Section 3.6.
3. Three copies of a comprehensive single-line diagram prepared and approved by a registered professional engineer. This information must comprehensively show the Facility Owner's intended configuration for operation including switching devices, transformers, protective devices, metering devices, capacitors, proposed conductor sizes, etc.

Duke Energy Midwest will review the information supplied with the NIOF and provide appropriate engineering and operational comments and/or concerns that must be addressed and jointly resolved with Duke Energy Midwest. This review will also include a summary addressing other tangible responsibilities and associated estimated costs the Facility Owner will incur as reflected in Section 9 of this document.

10.2. Facility Data/Including Equipment Ratings

At least three (3) months prior to the in-service date, Duke Energy Midwest shall receive the following data as listed below. If the data is not available three months prior to the in-service date, the Facility Owner shall provide estimates based on their design information. Such data shall be identified, as "estimated" and replaced with actual data by the Facility Owner as it becomes available prior to installation.

The purpose of Facility data to be provided to Duke Energy Midwest by the Facility Owner is to ensure proper coordination to protect against equipment or facility damage, to mitigate safety hazards to utility personnel and the public, and to minimize disturbances, impairment, or interference with Duke Energy Midwest's ability to serve other Transmission System users.

10.2.1. Data on Equipment to be Installed

- a. Interrupting Devices and Relays - Complete manufacturer's data for interrupting devices and relays or fuses used for the protection of the Duke Energy Midwest system and the Facility.
- b. Power Transformers - Complete nameplate or test sheet data, including manufacturer, serial number, high- and low-side voltage

Requirements for Connection of Facilities to the Duke Energy Midwest Transmission System

taps, kVA ratings, impedance, load loss and no load loss watts, high- and low-side voltage winding connections, low-side voltage winding grounding (if used), and high voltage inrush current.

- c. Power Capacitors - Location, kV and kVAr rating of capacitor banks, number of units, and bank configuration.
- 10.2.2. Data on the Facility protection equipment, including make-before-break transfer switches, fuses, breakers, relays, relay settings associated with the proposed Facility, and detailed schematic diagrams of protective relaying proposed for the Transmission System.

Complete manufacturer's data and specifications for make-before-break transfer switches, including transfer times and conditions of transfer, testing procedures, equipment schematics, and backup protection.
 - 10.2.3. Information on characteristics of load, such as initial and near future expected load (MW and MVAR), power factor of such load, voltage level at point of interconnection, and dynamic (Flicker, Harmonics, etc.) character of such load.
 - 10.2.4. Minimum and maximum required operating voltages.
 - 10.2.5. Generator Data (if applicable):
 - a. Type (synchronous, induction, dc with solid-state inverter, etc.)
 - b. Nameplate data and ratings, including any rectifying, regulating, or inverting equipment
 - c. Harmonic content at full rated output
 - d. Detailed Generation Dynamic Performance Data in accordance with the form in Appendix B.
 - e. Real and reactive capabilities at scheduled voltages.
 - 10.2.6 Electric one-lines and schematic diagrams showing the Facility, the Interconnection Facilities, the Transmission System, and the protective relaying.

11. INSPECTION REQUIREMENTS (EXISTING OR NEW)

Duke Energy Midwest personnel must inspect and approve the Facility before it can be energized. The inspection will focus on all substation equipment from the first protective fault-interrupting device to the Interconnection Point. This may include circuit breakers, circuit switchers, power fuses, instrument transformers, switches, surge arresters, bushings, relays and associated equipment (including battery and

Requirements for Connection of Facilities to the Duke Energy Midwest Transmission System

battery chargers). The inspection will consist of a visual inspection of all major equipment as well as review of required test results.

12. FINAL DOCUMENTATION

Duke Energy Midwest shall receive final documentation of the Facility that replaces the above specifications and data submitted for the design review under Section 10.2 once the Facility is ready for operation.

Prior to operation of a Facility, the Facility Owner shall supply to Duke Energy Midwest three copies of all-final electric one-line diagrams, equipment data, and schematic diagrams. Subsequent revisions affecting the Facility shall be documented with three copies of the revised electric one-line and schematic diagrams.

13. APPROVALS

Duke Energy Midwest reserves the right to review and approve/accept the equipment used, design, construction, testing, and maintenance of the protective equipment provided by the Facility for protection of the Transmission System.

Prior to the connection with, energizing of, or operation of the Facility, the Facility Owner shall obtain approval from or acceptance by Duke Energy Midwest for the Facility, electrical equipment specifications, and operating procedures.

Duke Energy Midwest will issue final approval for operation of the Facility. For generators and transmission interconnections, a signed Interconnection Agreement with Duke Energy Midwest is required for final approval of the interconnection and before connection of the Facility to the Transmission System. Duke Energy Midwest reserves the right to refuse operation of the Facility for failure of the Facility Owner to meet any of the requirements stated herein to Duke Energy Midwest's satisfaction.

Duke Energy Midwest's review, approval, or acceptance of the proposed Facility specifications, equipment, design, and plans shall not be construed as confirming or endorsing the design or warranting the safety, durability, reliability, adequacy, or otherwise of the Facility Owner's Facility.

14. SPECIAL PROVISIONS

Special provisions may be made with operators of small power production facilities and other co-generators pursuant to rules of the Federal and/or State agencies of the applicable regulatory jurisdiction.

15. COORDINATION WITH OTHER CODES, STANDARDS, AND AGENCIES

Requirements for Connection of Facilities to the Duke Energy Midwest Transmission System

The information contained in this document is supplementary to and does not intentionally conflict with or supersede the National Electric Code (NEC) as approved by the American National Standards Institute (ANSI) or such federal, state and municipal laws, ordinances, rules or regulations as may be in force within the cities, towns or communities in which Duke Energy Midwest furnishes electric service. It is the responsibility of the Facility Owner to conform to all applicable national, state and local laws, ordinances, rules, regulations, codes, etc.

16. INDEMNIFICATION

The Facility Owner, for itself, its successors, assigns and subcontractors will be required to pay, indemnify and save Duke Energy Midwest, its successors and assigns, harmless from and against any and all court costs and litigation expenses, including legal fees, incurred or related to the defense of any action asserted by any person or persons for bodily injuries, death or property damage arising or in any manner growing out of the use and reliance upon the information provided by Duke Energy Midwest. Reliance upon the information in this document shall not relieve the Facility Owner from responsibility for the protection and safety of the general public.

The use and reliance upon the information contained in this document shall in no way relieve the Facility Owner from the responsibility to meet NEC and NESC requirements governing their design, construction, operation, and materials.

APPENDIX A – Connections to Duke Energy Midwest System

Figure 1 Typical Connection to Existing Substations

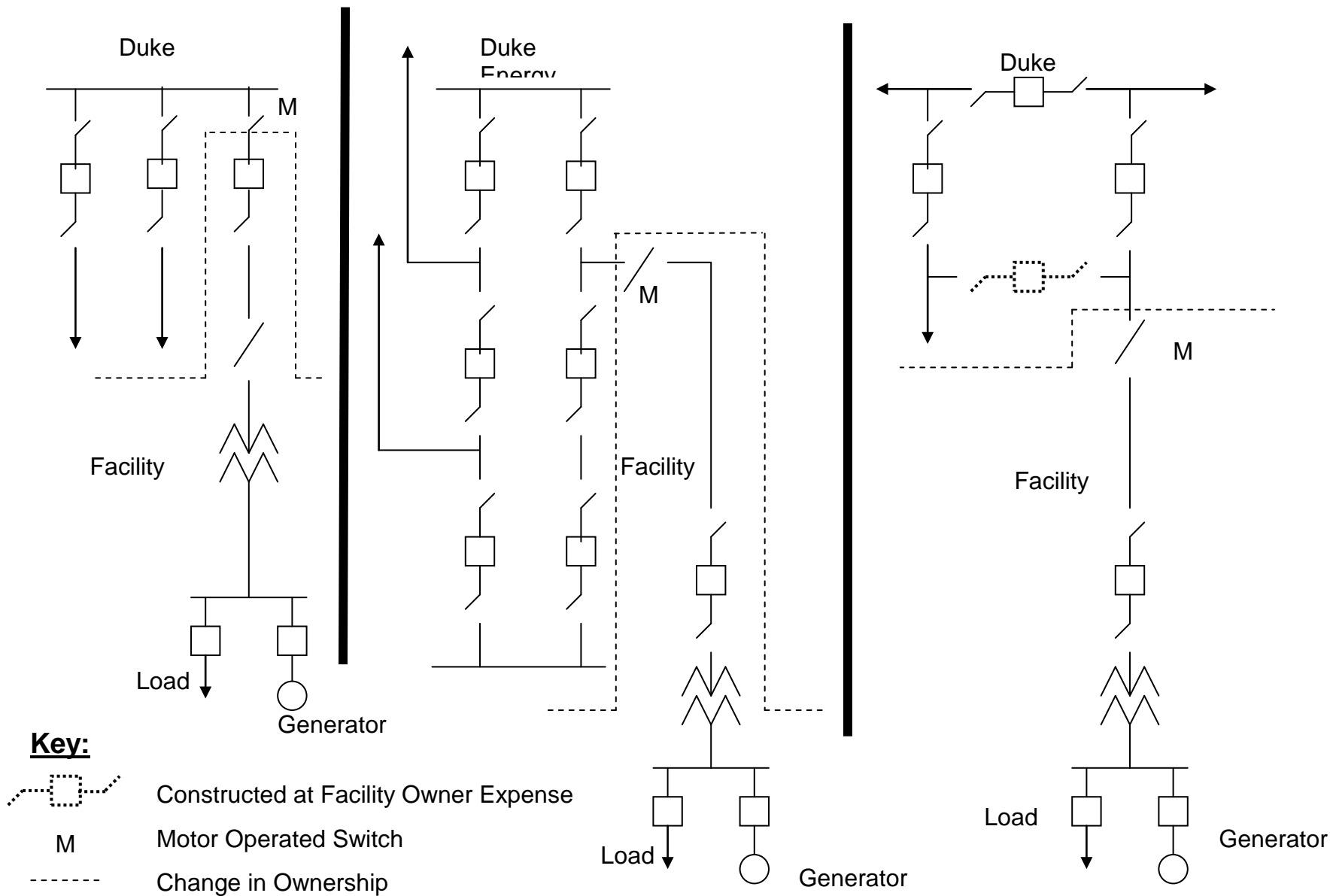
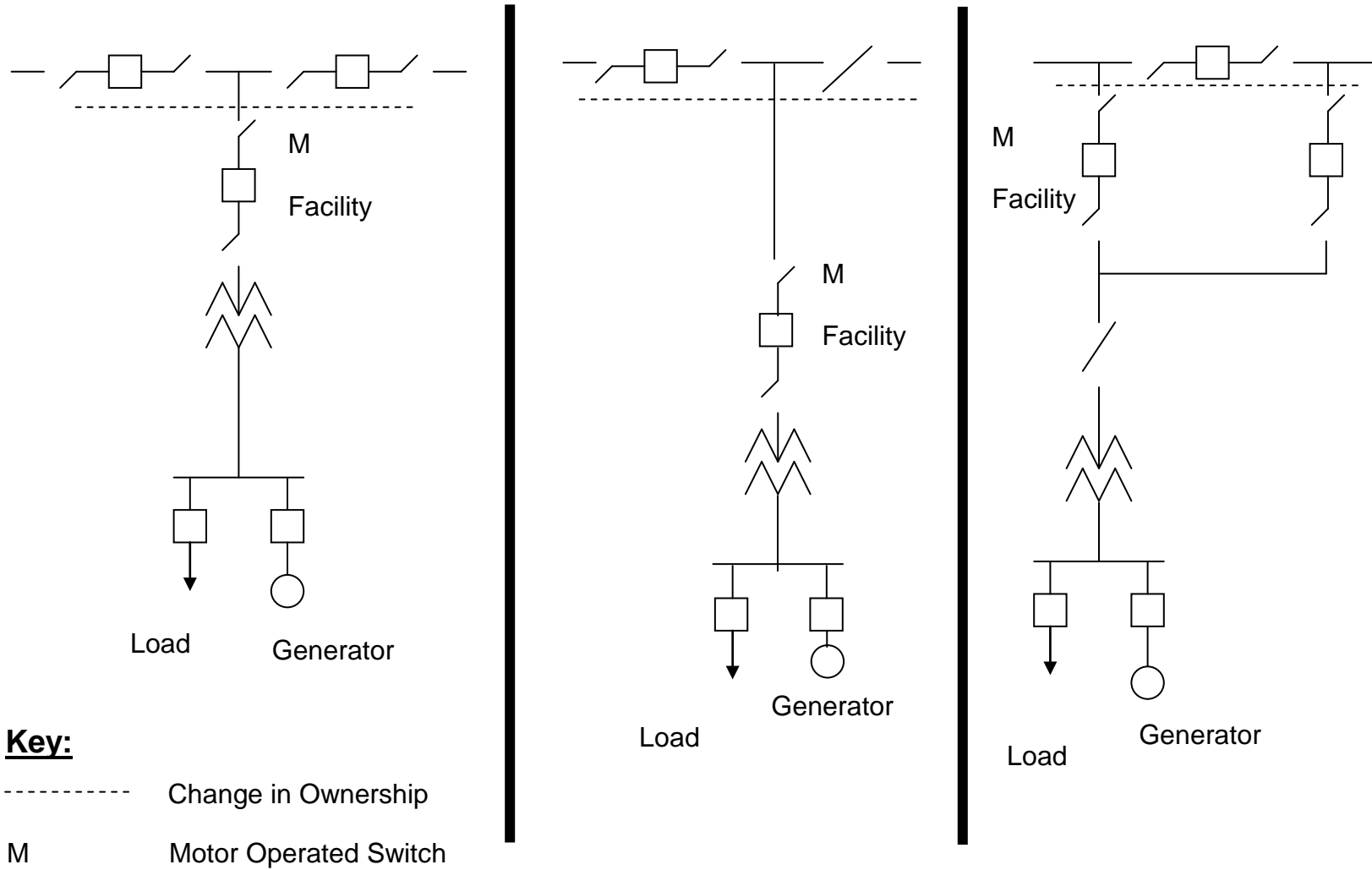

Figure 2 Typical Connection to Transmission Line



APPENDIX B – Generation Dynamic Performance Data

Requirements for Connection of Facilities to the Duke Energy Midwest Transmission System

Customer Name _____

Date ___/___/___

GENERATOR DATA

UNIT RATINGS

| | | | | | |
|-----------------------------|-------|-------|----|-----------------------|-------|
| kVA | _____ | _____ | °F | Voltage | _____ |
| Power Factor | _____ | _____ | | H ₂ psig | _____ |
| Speed (RPM) | _____ | _____ | | Connection (e.g. Wye) | _____ |
| Short Circuit Ratio | _____ | _____ | | Frequency, Hertz | _____ |
| Stator Amperes at Rated Kva | _____ | _____ | | Field Volts | _____ |

REACTANCE DATA (PER UNIT-RATED KVA)

DIRECT AXIS

QUADRATURE AXIS

| | | | | |
|---------------------------------|-------|-------|-------|-------|
| Synchronous – saturated | Xdv | _____ | Xqv | _____ |
| Synchronous – unsaturated | Xdi | _____ | Xqi | _____ |
| Transient – saturated | X'dv | _____ | X'qv | _____ |
| Transient – unsaturated | X'di | _____ | X'qi | _____ |
| Subtransient – saturated | X''dv | _____ | X''qv | _____ |
| Subtransient – unsaturated | X''di | _____ | X''qi | _____ |
| Negative Sequence – saturated | X2v | _____ | | |
| Negative Sequence – unsaturated | X2i | _____ | | |
| Zero Sequence – saturated | X0v | _____ | | |
| Zero Sequence – unsaturated | X0i | _____ | | |
| Leakage Reactance | Xlm | _____ | | |

FIELD TIME CONSTANT DATA (SEC)

| | | | | |
|---|-------|-------|-------|-------|
| Open Circuit | T'do | _____ | T'qo | _____ |
| Three-Phase Short Circuit Transient | T'd3 | _____ | T'q | _____ |
| Line to Line Short Circuit Transient | T'd2 | _____ | | |
| Line to Neutral Short Circuit Transient | T'd1 | _____ | | |
| Short Circuit Subtransient | T''d | _____ | T''q | _____ |
| Open Circuit Subtransient | T''do | _____ | T''qo | _____ |

ARMATURE TIME CONSTANT DATA (SEC)

| | | |
|-------------------------------|-----|-------|
| Three Phase Short Circuit | Ta3 | _____ |
| Line to Line Short Circuit | Ta2 | _____ |
| Line to Neutral Short Circuit | Ta1 | _____ |

ARMATURE WINDING RESISTANCE DATA (PER UNIT)

| | | |
|---|----|---------------------|
| Positive | R1 | _____ |
| Negative | R2 | _____ |
| Zero | R0 | _____ |
| | | |
| Rotor Short Time Thermal Capacity I ² t | = | _____ |
| Field Current at Rated kVA, Armature Voltage and PF | = | _____ amps |
| Field Current at Rated kVA and Armature Voltage, 0 PF | = | _____ amps |
| Three Phase Armature Winding Capacitance | = | _____ microfarad |
| Field Winding Resistance | = | _____ ohms _____ °C |
| Armature Winding Resistance (Per Phase) | = | _____ ohms _____ °C |

COMBINED TURBINE-GENERATOR-EXCITER INERTIA DATA (Provide one)

Requirements for Connection of Facilities to the Duke Energy Midwest Transmission System

Inertia Constant, H = _____ kW sec/kVA
Moment-of-Inertia, WR² = _____ lb. ft.²

CURVES

Saturation, Vee, Reactive, Capacity Temperature Correction

GENERATOR STEP-UP TRANSFORMER DATA

RATINGS

Capacity Self-cooled/maximum nameplate _____ / _____ kVA
Voltage Ratio Generator side/System side _____ / _____ kV
Winding Connections Low V/High V (Delta or Wye) _____ / _____ kV
Fixed Taps Available _____
Present Tap Setting _____
Load Tap Changer? _____ Yes _____ No
Range (+/-%) _____

IMPEDANCE

Positive Z1 (on self-cooled kVA rating) _____ %
Zero Z0 (on self-cooled kVA rating) _____ %

EXCITATION SYSTEM

Identify appropriate IEEE model block diagram of excitation system and power system stabilizer (PSS) for computer representation in power system stability simulations and the corresponding excitation system and PSS constants for use in the model. Also, identify the source(s) (e.g., vendor or field tests) of the model and modeling data.

GOVERNOR SYSTEM

Identify appropriate IEEE model block diagram of governor system for computer representation in power system stability simulations and the corresponding governor system constants for use in the model. Also, identify the source(s) (e.g., vendor or field tests) of the model and modeling data.

APPENDIX C – Voltage Flicker & Harmonic Distortion Criteria

Requirements for Connection of Generation Facilities to the Duke Energy Midwest
Transmission System

Duke Energy Midwest Voltage Flicker Criteria and Harmonic Distortion Criteria

This document summarizes Duke Energy Midwest policy on voltage Flicker and harmonic distortion for customers connected to the electrical system via a Company dedicated transformer or a Customer owned transformer. The term Company is defined as Duke Energy Midwest. The term Customer is defined as the Party connected to the Duke Energy Midwest system.

I. POINT OF COMPLIANCE – The point where the Company dedicated transformer or Customer owned transformer connects to the Company system will be the point where compliance with the voltage Flicker and harmonic distortion requirements are evaluated.

II. VOLTAGE FLICKER CRITERIA – The Company requires that the voltage Flicker occurring at the point of compliance shall remain below compatibility levels in LV systems and below planning levels in MV, HV, and EHV systems. Acceptance of Flicker emissions by the Facility Owner shall follow IEC 61000-3-7, “Assessment of emission limits for fluctuating loads in MV and HV power systems.” Compatibility levels for LV (≤ 1 kV) Flicker are Pst = 1.0 and Plt = 0.8. Planning levels for MV ($1\text{kV} < V \leq 35\text{kV}$) Flicker are Pst = 0.9 and Plt 0.7. Planning levels for HV and EHV ($> 35\text{kV}$) are Pst = 0.8 and Plt = 0.6.

The Facility Owner agrees it will adhere to these limits at the 99% compliance level. The Facility Owner further agrees that under no circumstances will it permit the Facility contribution to voltage Flicker to exceed the Duke Energy Midwest criteria, whether or not complaints are received or service/operational problems are experienced on the Duke Energy Midwest subtransmission or Transmission System. Should complaints be received by Duke Energy Midwest or other operating problems arise, or should the Facility Flicker exceed the Pst and Plt limits, the Facility Owner agrees to take immediate action to reduce its Flicker to a level at which Flicker complaints and service/operational problems are eliminated.

Corrective measures could include, but are not limited to, modifying production methods/ materials or installing, at the Facility Owner’s expense, voltage Flicker mitigation equipment such as a static var compensator. Duke Energy Midwest will work collaboratively with the Facility Owner to assess problems, identify solutions and implement mutually agreed to corrective measures.

If the Facility Owner fails to take corrective action after notice by Duke Energy Midwest, then Duke Energy Midwest shall have such rights as currently provided for under its tariffs, which may include discontinuing service, until such time as the problem is corrected.

III. HARMONIC DISTORTION CRITERIA - Duke Energy Midwest also requires that the Facility Owner’s operation be in compliance with the Duke Energy Midwest Harmonic Distortion Guidelines (see Exhibit 2). These requirements are based on IEEE Standard

Requirements for Connection of Facilities to the Duke Energy Midwest Transmission System

519, "IEEE Recommended Practices and Requirements for Harmonic Control in Electric Power Systems". In addition, the Facility's operation shall not cause interharmonic currents in excess of those limits for even Harmonics.

The Facility Owner agrees that the operation of motors, appliances, devices or apparatus served by its system and resulting in harmonic distortions in excess of Duke Energy Midwest's requirements will be the Facility Owner's responsibility to take immediate action, at the Facility Owner's expense, to comply with Duke Energy Midwest's Harmonic Distortion Requirements. Duke Energy Midwest will work collaboratively with the Facility Owner to assess problems, identify solutions and implement mutually agreed to corrective measures.

If the Facility Owner fails to take corrective action after notice by Duke Energy Midwest, then Duke Energy Midwest shall have such rights as currently provided for under its tariffs, which may include discontinuing service, until such time as the problem is corrected.

APPENDIX D – Generation Abnormal Frequency Allowance

Requirements for Connection of Facilities to the Duke Energy Midwest Transmission System

Typical Generator Requirement for Voltage & Frequency Operational Range

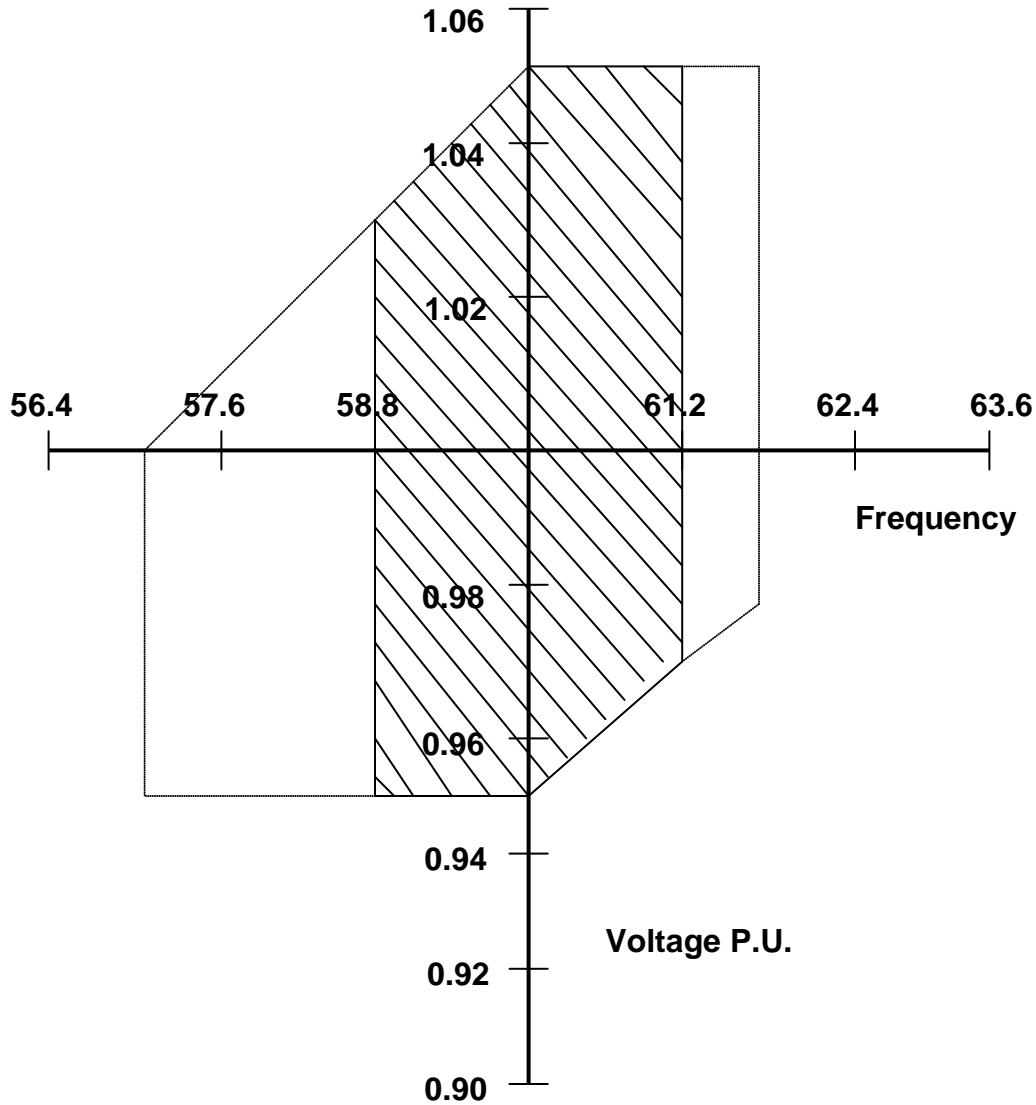

Continuous Operation of the Generation is expected within the hatched area of the above graph. Operation is also expected within the dotted area with limited time duration without loss of the Facility. Manufacturer ratings may vary and must be submitted to Duke Energy Midwest for acceptance before operational connection requirements are fulfilled.

Appendix E – Revision Record



NERC Standards Compliance Document

| | |
|--------------------------------|---|
| Document Title | Duke Energy Midwest Facility Connection Requirements |
| Purpose | This document outlines the minimum requirements for all facilities connection to the Transmission System. |
| Applicability | TO |
| References | FAC-001-0 |
| Document Owner/Approver | Ed Kirschner |
| Date Approved | June 3, 2009 |
| Effective Date | August 14, 2000 |

| Date | Version | Changed By | Pages or Sections Revised and Description |
|-----------|---------|---------------|--|
| 8/14/2000 | 0 | | Original |
| 9/1/2003 | 1 | | Add End User Facility Requirements |
| 9/25/2006 | 2 | Jim Doell | Change Company Name to Duke Energy |
| 6/3/2009 | 3 | Jeff Gindling | Updates to reflect new MISO Interconnection process and NERC Standards |
| 9/1/2009 | 4 | Jeff Gindling | Updates to clarify Section contents |